

WOOFER L18P200-N

Professional Low Frequency Transducer

The L18P200 is the RCF classical extended low frequency 18" woofer. Generous voice coil length, heavier moving mass weight and very low resonance for perfect low frequency reproduction. Remarkable the linearity in the application range. Special treatments are applied to cone surface and surround for optimum dampening.

PART NUMBER **11185012**

Features

- 4-inch, Kapton former copper voice coil
- 1600 Watt continuous program power handling
- 96 dB Sensitivity
- 27 Hz - 1 kHz Frequency range
- Triple roll damped surround
- Corrugated straight damped cone

Applications

The L18P200N finds its best application in bass reflex enclosures. It is a perfect solution for recorded music, cinema subwoofers, very low frequency monitoring and applications where very low frequency linearity is required.



27 1000

20

100

1.000

10.000

20.000

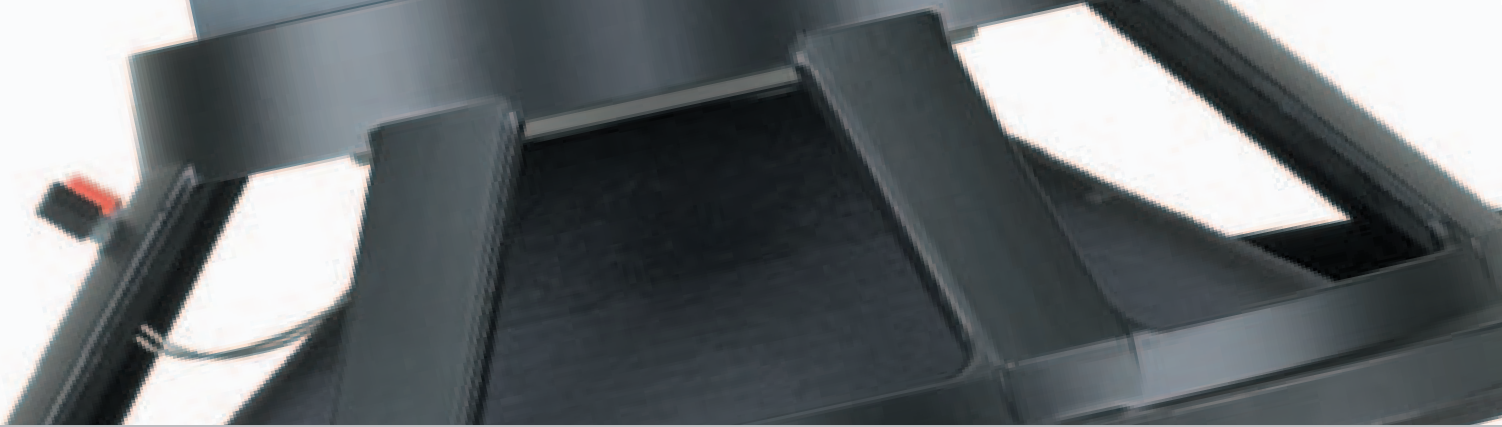

8 x ϕ 8 holes to 45°
on 456 mm

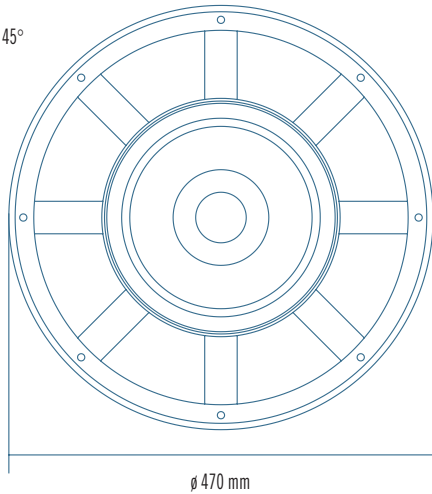

ϕ 470 mm

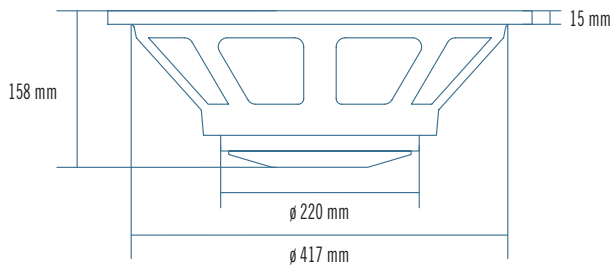

158 mm

ϕ 220 mm

ϕ 417 mm

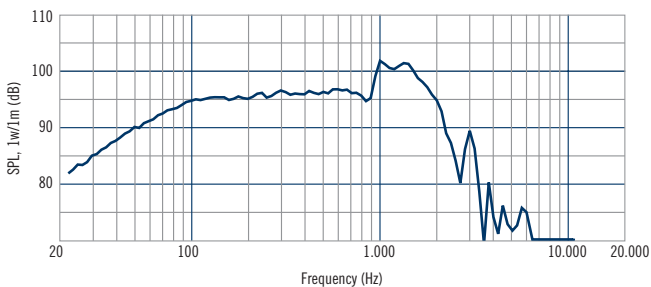

Frequency response curve of the loudspeaker taken in a hemispherical, free field environment and mounted in a closed box with an internal volume of 600 litres (21.2 cu.ft) enclosing the rear of the driver.

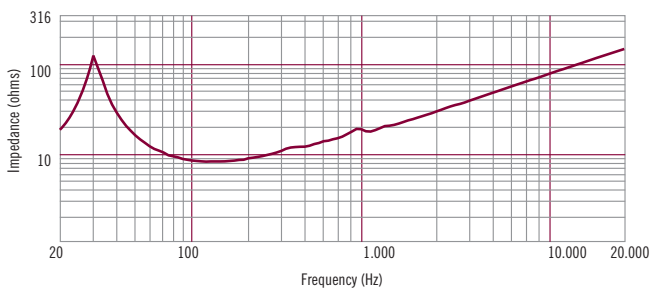

Impedance magnitude curve measured in free air.

General Specifications

Nominal Diameter	460/18	mm/inch
Rated Impedance	8	ohm
Program Power ¹	1600	Watts
Power handling capacity ²	800	Watts
Sensitivity ³	96	dB
Frequency Range	27 - 1000	
Effective Piston Diameter	380/15	mm/inch
Max Excursion Before Damage (peak to peak)	36/1.4	mm/inch
Minimum Impedance	7.5	ohm
Voice Coil Diameter	100/4	mm/inch
Voice Coil Material	Copper	
Voice Coil Winding Depth	24/0.9	mm/inch
Number of layers	2	
Kind of layer	outside	
Top Plate Thickness	9/0.35	
Cone Material	No pressed pulp treat	
Cone Design	Straight	
Surround Material	Polycotton treat	
Surround Design	Triple roll	

Thiele - Small Parameters ⁴

Resonance frequency	Fs	28	Hz
DC resistance	Re	6.3	ohm
Mechanical factor	Qms	7.1	
Electrical factor	Qes	0.32	
Total factor	Qts	0.31	
BL Factor	BL	23.1	T - m
Effective Moving Mass	Mms	155	gr
Equivalent Cas air load	Vas	380	liters
Effective piston area	Sd	0.113	m ²
Max. linear excursion (mathematical) ⁵	Xmax	9.8	mm
Voice - coil inductance @ 1KHz	Le1K	2.2	mH
Half-space efficiency	Eff	2.51	%

Mounting Information

Overall Diameter	470/18.5	mm/inch
Bolt Circle Diameter	438	mm/inch
Bolt Hole Diameter	8/0.3	mm/inch
Front Mount Baffle Cut-out	416/16.4	mm/inch
Rear Mount Baffle Cut-out	418/16.5	mm/inch
Depth	180/7.1	mm/inch
Volume occupied by the driver ⁶	6.2	liters/ft ³

Shipping Information

Net Weight	13.1/29.1	Kg/Lbs
Shipping Weight	13.8/30.7	Kg/Lbs

Notes to Specifications

¹ Program Power is defined as 3 dB greater than AES power. - ² AES standard. - ³ Sensitivity measurement is based on a 100-500 Hz pink noise signal with input power of 2.83V @ 8 Ohms. - ⁴ Thiele-Small parameters are measured after a 2 hour warm up period running the loudspeaker at full power handling capacity. - ⁵ The maximum linear excursion is calculated as: $(Hvc - Hg)/2 + Hg/4$ where Hvc is the voice coil depth and Hg the gap depth. - ⁶ Calculated for front mounting on 18 mm thick board.