

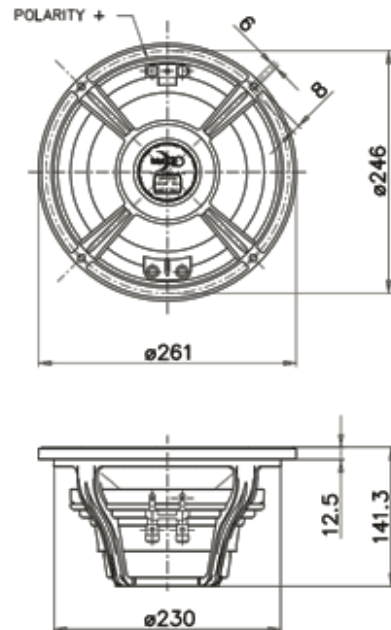

# 10HP1020 High Performance Series



## NOMINAL SPECIFICATIONS

Nominal Diameter	250 mm (10 in)
Overall Diameter	261 mm (10.28 in)
Bolt Circle Diameter	246 mm (9.69 in)
Baffle Cutout Diameter	232 mm (9.13 in)
Depth	141.3 mm (5.56 in)
Flange and Gasket Thickness	12.5 mm (0.49 in)
Net Weight	5.2 Kg (11.44 lb)
Shipping Box (Single Carton Box)	305x305x185 mm (12x12x7.28 in)
Shipping Weight	5.8 Kg (12.76 lb)

## ELECTRICAL SPECIFICATION

Minimum Impedance	7.3 Ohm
Nominal Impedance	8 Ohm
Nominal Power Handling *	700 W
Maximum Power Handling **	1400 W
Sensitivity (1W/1m)	96 dB
Frequency Range	60÷4000 Hz
Voice Coil Diameter	100 mm (4 in)
Winding Material	Al
Former Material	Glass Fiber
Winding Depth	22 mm (0.87 in)
Magnetic Gap Depth	12 mm (0.47 in)
Flux Density	1.3 T

## THIELE & SMALL PARAMETERS

Fs	60 Hz
Re	5.5 Ohm
Bl	25.7 N/A
Mms	72.5 g
Cms	0.096 mm/N
Rms	4.58 Kg/s
Qes	0.22
Qms	6.01
Qts	0.23
Vas	15.65 dm <sup>3</sup> (0.55 ft <sup>3</sup> )
Sd	339 cm <sup>2</sup> (52.5 in <sup>2</sup> )
Xmax ***	9 mm
Xdamage ****	12.5 mm
Le	0.85 mH
Mmd	69 g
Eta Zero	1.46 %

## ORDERING CODES

Push Terminals - 8 Ohm Version	02503939
Faston Terminals - 8 Ohm Version	02503949

## NOTES

(\*) 2 Hours Test According to AES 2-1984 Rev. 2003

(\*\*) Maximum power is defined as 3dB greater than nominal power.

(\*\*\*)  $X_{max} = [(winding\ depth - magnetic\ gap\ depth) / 2] + (magnetic\ gap\ depth / 3)$

(\*\*\*\*) Maximum excursion before permanent damage

# CURVES

---

