

CP12/N

HIGH FREQUENCY COMPRESSION DRIVER



The model CP 12/N is a professional lightweight compression tweeter, featuring an aluminium voice coil-diaphragm assembly. This device has a smooth response in all its frequency ranges with an incredibly high sound pressure (107 dB), as well as a narrow controlled dispersion for long throw applications. This models is well suited for use in two or three-way compact size enclosures. The diaphragm assembly is field replaceable without soldering.

Modelo similar al CP16, pero con una eficiencia mayor gracias a la utilización de una bobina de hilo plano de aluminio y a un optimizado diseño. Su aplicación principal es en instalaciones de exteriores, pero puede ser utilizado con mucho éxito en sistemas semiprofesionales y de alta fidelidad.

SPECIFICATIONS

Rated impedance	8 ohms.
Minimum impedance	8 ohms @ 8 kHz
D.C. Resistance	5 ohm
Power capacity*	15 w RMS
Program Power	30 Watts.
Sensitivity**	107 dB 1w @ 1m.
Frequency range	3 - 20 kHz
Recommended crossover	6 kHz, 12 dB/oct. min.
Dispersion H x V	40° conical
Voice coil diameter	25.8 mm. 1 in.
Magnetic assembly weight	0.7 kg. 1.54 lb.
Flux density	1.4 T
BL Factor	4 N/A

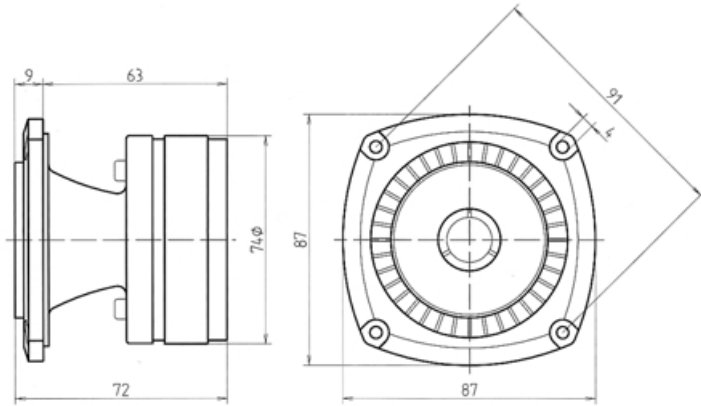

MOUNTING INFORMATION

Overall diameter	87 x 87 mm. 3.4 x 3.4 in.
Depth	72 mm. 2.83 in.
Baffle cutout dimensions	ø 74 mm. 2.9 in.
Bolt circle diameter	91 mm. 3.58 in.
Net weight	0.75 kg. 1.65 lb.
Shipping weight	0.85 kg. 1.87 lb.

POLAR PATTERN

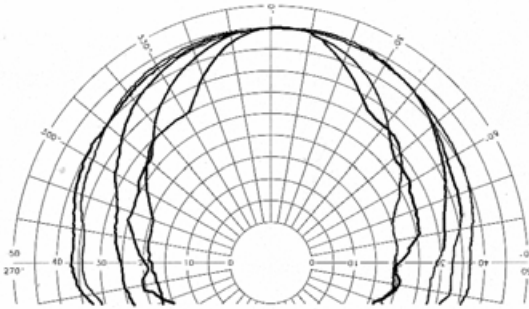

MATERIALS

Diaphragm	Aluminium
Voice coil	Edgewound alum. ribbon
Voice coil former	Nomex
Magnet	Ferrite

FREQUENCY RESPONSE & DISTORTION CURVES, MAGN. On axis, 1w @ 1m.

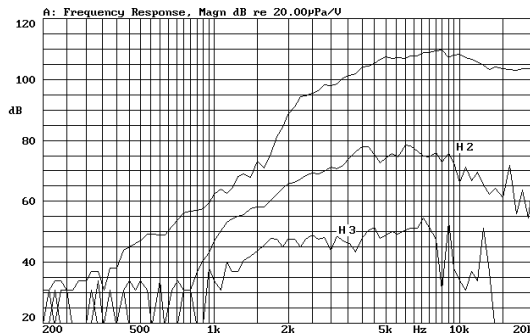

TIME RESPONSE, MAGN.

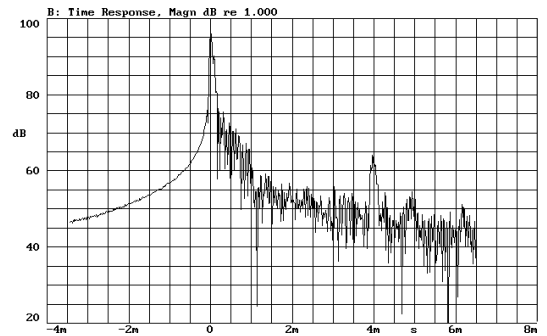

FREQUENCY RESPONSE, PHASE. On axis, 1w @ 1m.

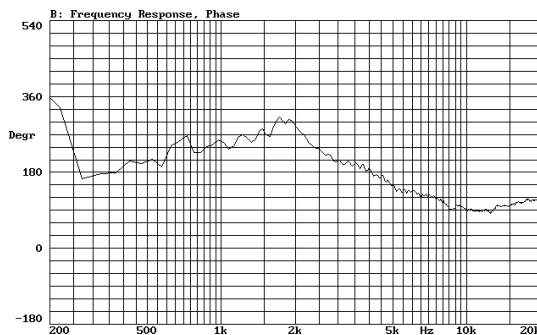

FREE AIR IMPEDANCE CURVE

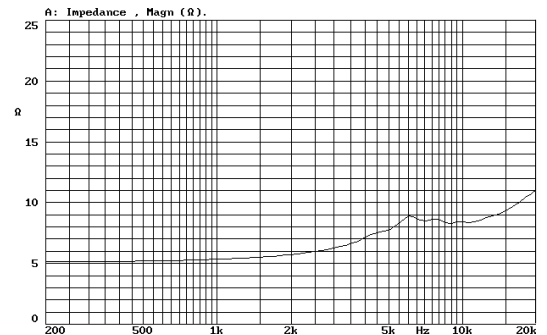

NOTES
 *The power capacity corresponds to the RMS maximum value that can dissipate the loudspeaker when a sinus signal is applied for a period of at least two hours.
 Program power is defined as the transducer's ability to handle normal music program material.
 **Sensitivity was measured at 1m distance, on axis, with 1w input, averaged in the range 3-15 kHz.

NOTAS
 * La potencia admisible corresponde a la máxima potencia RMS que puede disipar el altavoz durante al menos dos horas, cuando se le aplica una señal determinada. Por potencia programa se entiende la capacidad de altavoz en el manejo de señales transitorias como sería el proporcionado por el contenido de un pasaje musical normal.
 **Medición realizada con el microfono a 1 m de distancia, en el eje, aplicando 1w al altavoz, promediando en el rango 1-7 kHz.